

Get a head start on your organizing by filling out our simple checklist. Then bring it with you for your one-on-one consultation with our experienced organizers.

Please provide some basic measurements of your bedroom closet.

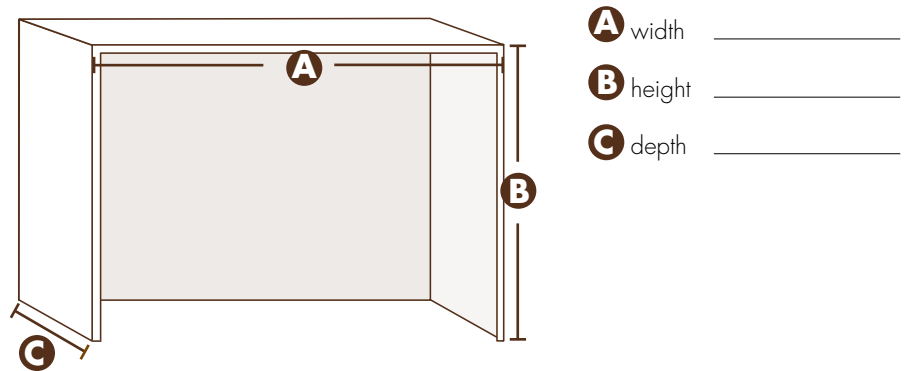

How much space do you need for your long items (suits, dresses, coats, etc.)?

- 0 - 12" 12"-18" 18" - 24" over 24"

How much space do you need for your short items (shirts, skirts, etc.)?

- 0 - 12" 12"-18" 18" - 24" over 24"

How many shelves do you currently use for folded clothes?

- None 1 - 3 4 - 6 More than 6

How many pairs of shoes do you need room for?

Do you require any drawers? If so, how many do you use currently?

Do you hang your pants by the cuff or folded over?

Do you need a full length mirror?

Home Solutions

11510 - 40 Street SE
Calgary, AB T2Z 4V6
Tel: (403) 216-0000
Fax: (403) 216-0018
reception@closetsandglass.com
www. closetsandglass.com

Please bring this sheet in with you when you visit one of our consultants.